



TESTING TESTACAL

TEMPERATURE AND HUMIDITY TESTING CHAMBER
SPECIALLY DESIGNED FOR CALIBRATION, METROLOGY
AND QUALITY CONTROL





ARALAB is a company specialised in designing, developing, manufacturing and servicing of high quality climatic chambers and controlled environment rooms.

Since 1985 we have been perfecting ways to create and control temperature, humidity, light, air flow and many other environmental conditions.

Only the highest quality components are used to manufacture our chambers so customers can have the best equipment for their research and testing purposes.

Control the Environment. Your Own Climate.



Aralab Testing chambers have been the preferred solution of several ISO 17025 calibration laboratories and quality control institutions in Europe.

COMMON APPLICATIONS INCLUDE:

- Metrology
- Calibration
- Quality Control
- Environmental Testing

KEY FEATURES

- The most advanced technology in climatic control
- Internal aerodynamic optimization that ensures highly uniform and stable climatic conditions
- Time saving features with easily configurable testing programs that can run, start and stop automatically
- Highly resistant stainless steel interior for maximum durability and easy cleaning
- Flexible interior with height adjustable and removable stainless steel shelves
- Non-polluting construction and cooling system
- Compliant with international standards and requirements EN, IEC, DIN, ISO, NP and UNE



Certified ISO:9001 for its Quality Management System
 Certified ISO:14001 for its Environmental Management System

TECHNICAL INFORMATION

AVAILABLE MODELS	TEMPERATURE RANGE	HUMIDITY RANGE
TestaCal 300 ECP 20	-20°C to +180°C	10% to 98% RH
TestaCal 300 ECP 45	-45°C to +180°C	10% to 98% RH

TEMPERATURE AND HUMIDITY PERFORMANCE

TESTA CHAMBERS PERFORMANCE	UNITS	TESTACAL CT 300 -20	TESTACAL CT 300 -45
PERFORMANCE IN TEMPERATURE TESTING			
Temperature range			
Min	°C	10	10
Max	°C	90	90
Temperature uniformity (1a) (2)			
in Space @ low temp. point	°C	± 0,5	± 0,7
in Space @ 0°C	°C		± 0,50
in Space @ +25°C	°C		± 0,20
in Space @ +50°C	°C		± 0,30
in Space @ +75°C	°C		± 0,60
in Space @ high temp point (1b)	°C	± 1,5	± 1,5
Max. According to IEC60068-3-5	°C		± 1,5
Temperature fluctuation in time	°C		± 0,1°C to ± 0,3°C
Temperature change rate (2a) (2b)			
cooling	K/min	2	3
heating	K/min	2	5
PERFORMANCE IN HUMIDITY TESTING			
Humidity range			
Min	%rH	10	10
Max	%rH	98	98
Humidity uniformity (1a) (2)			
in Space @ +20°C 10%rH	%rH		± 0,5
in Space @ +20°C 30%rH	%rH		± 0,7
in Space @ +20°C 50%rH	%rH		± 0,8
in Space @ +20°C 70%rH	%rH		± 0,8
in Space @ +20°C 98%rH	%rH		± 0,9
Max. According to IEC60068-3-5	%rH	± 2	± 2
Humidity fluctuation in time	%rH	± 1	± 1
DIMENSIONS			
Test space volume	liters		272
Shelves			
number of shelves included (more can be added)	#		2
maximum weight load per shelf	kg		25
Entry ports			
Included as standard (more can be added)	units		1
Diameter (other diameters available)	mm		Ø80
Weight (approximately)	Kg	470	535
POWER & REFRIGERATION			
Supply voltage	V	1/N/PE 230V±10% 50Hz-60Hz	3/N/PE AC 400V±10% 50Hz-60Hz
Nominal Power	kW	4	11
Type of Refrigeration (air or water cooled)			
Air			Standard
Water			Optional
Type of Refrigerant			R449A
NOISE			
Noise levels	dBA		55 to 64 dBA



Performances measured in factory with ambient temperatures between 20°C and 25°C

(1a) Measurements with empty chamber and no optional accessories; (1b) in temperature range up to 150°C;



(2) According to IEC/EN 60068-3-5. Values will vary with TESTA/TESTACAL model, internal volume, compressor type and condenser cooling system. Temperature rate of change can be adjusted to comply with the needed heating / cooling speed requirements.

DIMENSIONS AND DRAWINGS

● ● ● ● TESTACAL 300

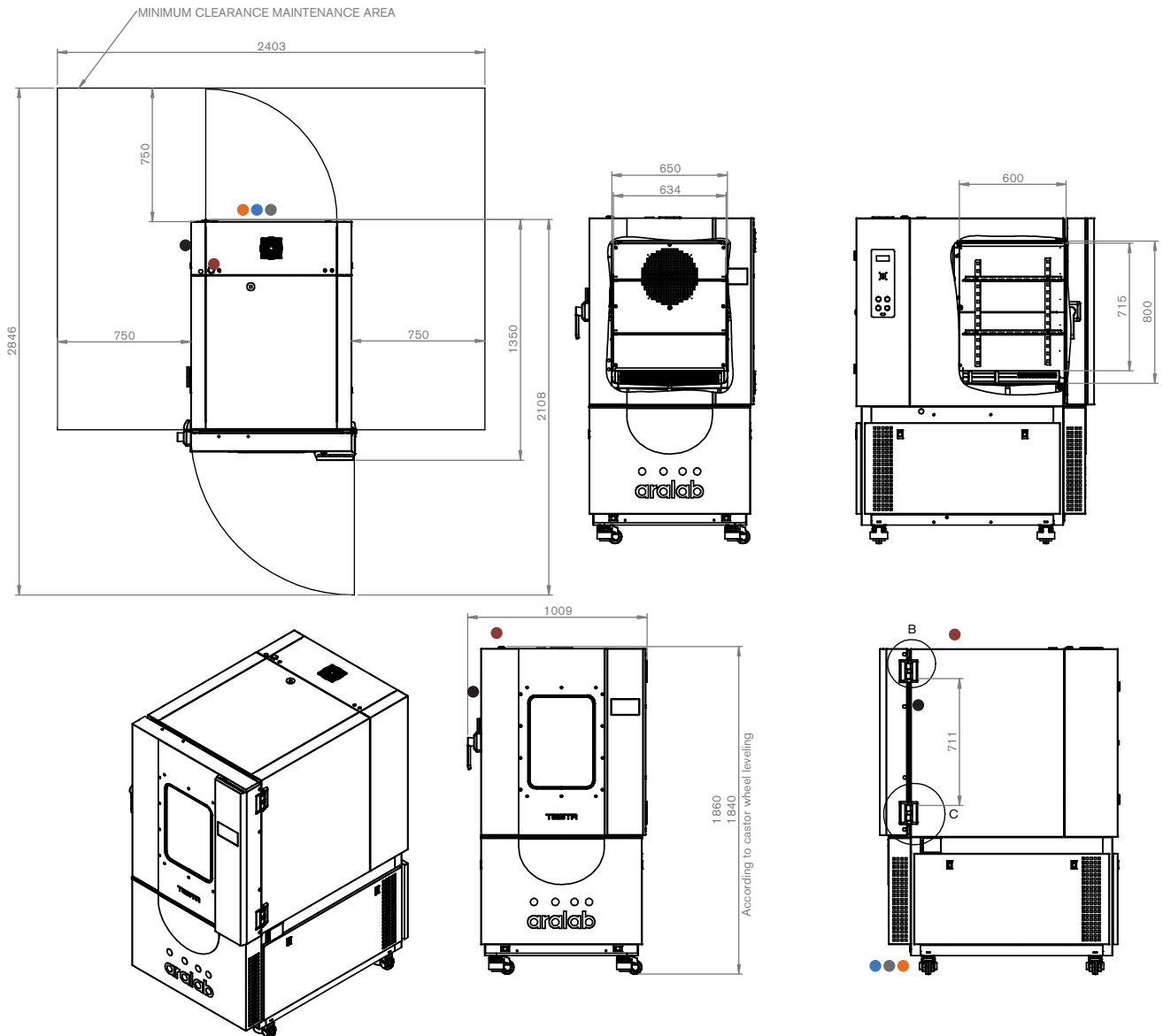

EXTERNAL DIMENSIONS (HxWxD) (mm)		1.830 x 980 x 1.340
INTERNAL DIMENSIONS (HxWxD) (mm)		800 x 650 x 600
INTERNAL NET VOLUME (LITERS)		272



- Standard refrigeration system is air cooled
- Services hub installation needs:
 -  1/2" demineralized water supply (for models with humidity control)
Conductivity: <math>< 50\mu\text{S}/\text{cm}</math>
 -  50mm water drain at floor level
- Electrical cabinet installation needs:

Supply power ECP20:
230VAC, 50Hz, 16A / Single Phase + Neutral + Ground
Electrical protection: Circuit breaker 16A + N with 300mA differential
Single Phase electrical cable RV-K 3G2,5 on the top

Supply power ECP45:
400VAC, 50Hz, 16A / 3-Phase + Neutral + Ground
Electrical protection: Circuit breaker 3 x 16A + N with 300mA differential
3-Phase electrical cable RV-K 5G4 on the top

-  RJ45 (Ethernet) communications port
 -  Water Cooled option
(standard TestaCal models are Air Cooled, but Water Cooled Condensers are also available):
Water flow: up to 2000 l/hr (at 25 °C)
Intake pressure: 2 to 5 bar
Water entry and exit pipe: 1" or 28mm
Differential pressure between entry and exit: $\geq 2,5$ bars
Maximum temperature of water entry: 26 °C
Minimum temperature of water entry: 16 °C
Recommended temperature of water entry: 18 °C

EQUIPMENT DESCRIPTION



TEMPERATURE

TEMPERATURE SENSORS

- One (1) PT 100 Class A, located in air treatment tunnel
- One (1) PT 100 Class A, movable sensor for flexible placing inside chamber

HEATING

- By tubular stainless steel electric heaters located in the air treatment tunnel

COOLING

- By airtight mechanical Scroll compressor group with enforced ventilation and without CFC's.
- As an option the system can be cooled by an air / water condenser. Air is used by default and only in need of greater power is water used, thus increasing efficiency.

SECURITY

- Safety thermostat with High / Low temperature configuration, with automatic stop of all heating systems. Alarms programmed in the controller, with mute function. This function won't stop the chamber and it's only used to record the occurrence and to call the attention of the users with an audible alarm.



HUMIDITY

HUMIDITY Sensors

- To measure and control humidity, Aralab has integrated 2 humidity measurement sensors: Psychrometric and Capacitive, simultaneously.

HUMIDITY / DRYING

- Humidity: Through thermostatic bath with dew point control.
- Drying: Through thermostatic bath with dew point control and additional dry coil

SECURITY

- Automatic stop function in case of water failure, with indication on the controller;
- Configurable High / Low Temperature alarms; High / Low humidity alarms.

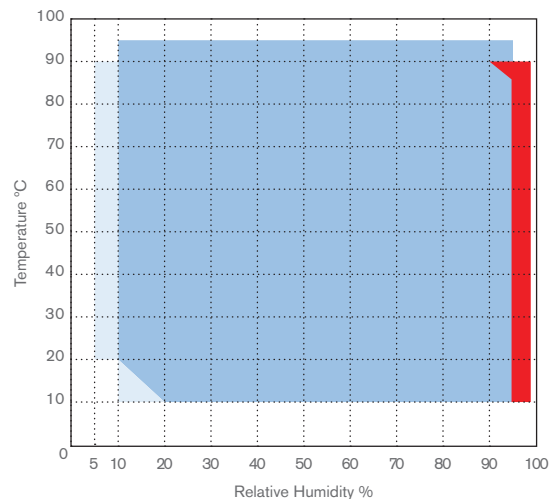

- Standard Climatic range 10%-98%rH and 10°C-95°C (only in TESTA -45C)
- Climatic range with upgraded drying capacity (please consult Aralab)
- Climatic range suitable for psychrometric sensor >95%rH

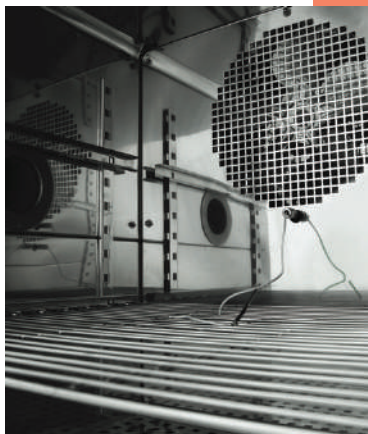

CONSTRUCTION

- Interior: AISI 304 hermetical welded, vapour tight, stainless steel
- Exterior: Zinc mild steel with epoxy coating finish (RAL 7035)
- Rock wool insulation
- Interior illumination by 12V halogen lamp (only available with optional window)
- Door: Double silicone joints and anti-condensation heating frames. Automatic electric locks with emergency opening from the inside
- 80 mm Ø side port for passing cables or other devices
- Height leveling casters

AIR FLOW / VENTILATION

- Forced through 1 ventilator/fan mounted at the top back end of the chamber.
- Air Renovation: By lateral port, also for compensating pressure

COMMON ACCESSORIES

PLEASE CONSULT ARALAB FOR OTHER ITEMS

FitoLog and FitoLogView Software pack

Anti-condensation observation window in multi layered glass

Water demineralizer

Water conductivity monitor

Additional entry side-ports

Calibration certificates from accredited external laboratory

Heating / Cooling temperature change rate speeds



Door with observation window



Compressed Air Dryer



Reinforced Shelves (up to 100 Kg load)



Additional Entry-ports



Water Treatment systems



Electronic safety locks



Water supply tank

CLIMAPLUS HMI CONTROLLER

Programmable PLC exclusively developed for ARALAB chambers

Easy to use coloured Touch-Screen Display Interface

Resolution of 0,1°C for Temperature and 0,1% for Relative Humidity

High performance temperature and humidity control with value correction in all ranges

Capability for creating 50 programs of 50 segments each

Internal non volatile memory for storing test data

Automatic restart of tests due to power failure, without losing data and restarting test where it was interrupted

Real-time monitoring of all functions and control of equipment.

Manage control settings via MODBUS/TCP

Possibility of programming a delay of the beginning of test

Monitoring and recording of all alarms

Possibility of performing events by external commands

Several outputs for connecting computers or other devices

Alarms management

Graphic representation of the tests and conditions

Remote access through VNC server

Possibility of running computer test programs and export them to the controller

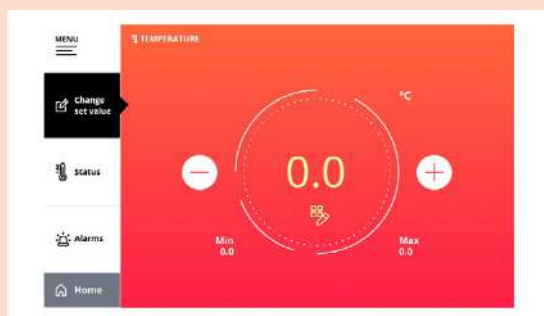
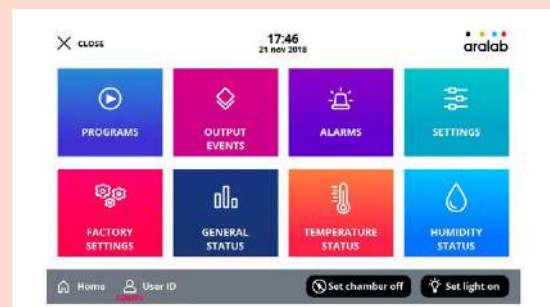

FITOLOG SOFTWARE

The FitoLog software pack is a set of applications designed to facilitate the managing, monitoring and recording of programs and data from the TESTA chambers. It consists of 3 applications: **FitoLog**, **FitoLogView** and **FitoProgram**.



FITOLOG

Records and displays in real time all data and details related to the set-points, running variables and equipment behaviour. It also retrieves information about the active components of the chamber, running processes, errors, alarms and allows the configuration of periodic or alarm triggered remote notifications (by email or SMS, depending on existing connections and accessories).

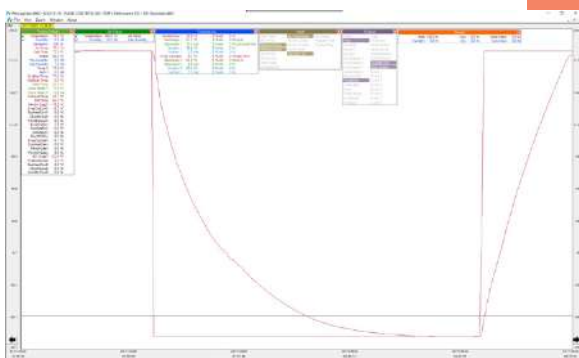

FITOLOGVIEW

It is a working tool to process the data recorded by the FitoLog program. One can view, print and export the log contents to other file types, and analyse the data in other data management software (Excel, Star Office, Access or others).

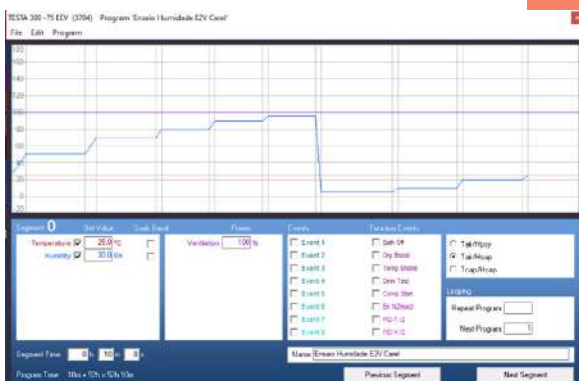

FITOPROGRAM

This application simplifies the creation of programs and its integration on the chamber ClimaPlus controller. Up to 32 programs, each with 24 segments, can be designed and linked to create detailed environmental profiles and simulations.

NOTIFICATIONS, FAST DIAGNOSTICS AND PROMPT TROUBLESHOOTING

With FitoLog it is possible to gather data from each of the chambers systems, which makes it a very useful tool to diagnose any necessary maintenance. This tool works as the "black box" of the equipment, giving Aralab technicians the necessary data to remotely carry out a fast and efficient diagnostic. All that is needed is a FitoLog file.

Let's meet!

aralab@aralab.pt

www.aralab.pt

T: +351 219 154 960



Configure your
FitoClima chamber

See it on the
Showroom

[f/AralabChambers](https://www.facebook.com/AralabChambers)

[in/company/aralab](https://www.linkedin.com/company/aralab)

[y/user/AralabChambers](https://www.youtube.com/user/AralabChambers)

[X/Aralab_](https://www.instagram.com/Aralab_)

[@aralabchambers](https://www.instagram.com/aralabchambers)

Distribuito da:

GEASS Srl

Via Ambrosini 8/2 10141 Torino

Tel: 011 2291578

Mail: commerciale@geass.com



Control the environment

Your own climate